

Service Bulletin



Information for Service Mgr. Shop Foreman Parts Mgr. Mechanics

JAN. 29, 1959

TO ALL CHRYSLER AND IMPERIAL DEALERS:

NO. 59-33

The enclosed bulletin covers the data and specifications of the 1959 Chrysler 300-E.

The information contained in this bulletin supplements the general service information in the 1959 Chrysler and Imperial Service Manual Supplement. This information covers in detail the specific data and specifications of the 1959 Chrysler 300-E engine and in particular the two 4-barrel carburetors, full race camshaft, special intake manifold, low restriction air cleaners, heavy duty valve springs and dampers, as well as other features exclusive with the 1959 Chrysler 300-E.

MISCEL-
LANEOUS

DATA AND
SPECIFICA-
TIONS

C. T. McClure

C. T. McCLURE
Director of Service
CHRYSLER DIVISION

CHRYSLER

ALL 1959

300-E

MODELS

1312

CONTENTS

<u>Name</u>	<u>Page</u>
Accessory Belt Drives	4
Body and Sheet Metal.	15
Brakes.	4
Cooling System.	4
Electrical System	7
Engine.	4
Frame	12
Fuel and Exhaust Systems.	7
General Data and Specifications	3
Heater - Air Conditioning	16
Lubrication	16
Radio and Heater.	16
Rear Axle	4
Steering.	12
Suspension.	3
TorqueFlite Transmission.	13
Universal Joints and Propeller Shaft.	15
Wheels and Tires.	15

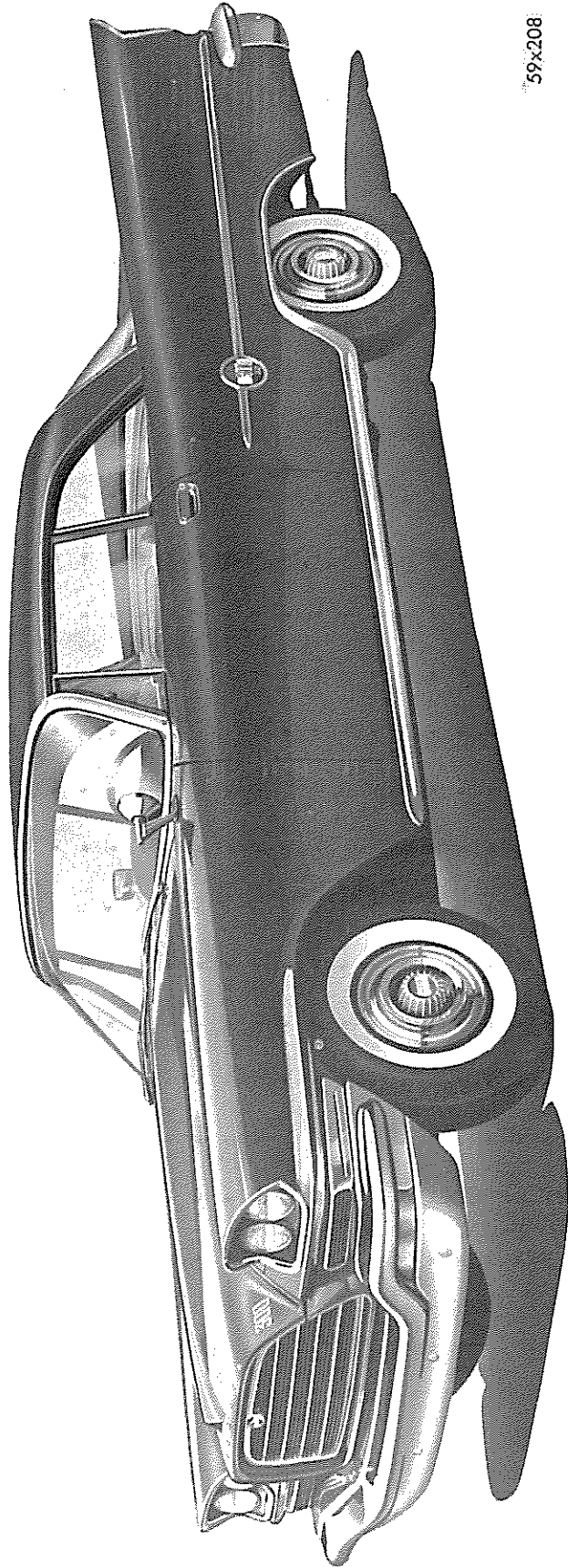

59x208

Fig. 1 - C-300E Sport Coupe Two Door Hardtop

1959 CHRYSLER - 300-E

GENERAL DATA AND SPECIFICATIONS

Item	Body Style
<u>Sports Coupe Two-Door Hardtop and Convertible Coupe</u>	
Wheelbase	126 inches
Tread (Front)	61.2 inches
Tread (Rear)	60.0 inches
Length with Bumper.	220.9 inches
Width with Bumper	79.5 inches
Height	55.2 inches
Rear Axle Ratio	3.31
Tire Size	9.00 x 14

1. SUSPENSION

FRONT SUSPENSION

The Front Wheel Suspension System is of the same basic design as used in Model MC-3, with the following exception:

THE FRONT SUSPENSION HEIGHT

The difference in the height between the floor and the two measuring points on each lower control arm (lowest point on ball joint housing and underside of bushing housing between flanges of arm) should be 1 7/8". This height must be maintained \pm or - 1/8 inch with a maximum differential from right to left of 1/8 inch.

REAR SUSPENSION

The Rear Springs differ from the MC-3 only in the rate of deflection.

TRUE-LEVEL TORSION-AIRE

The Air Suspension System is identical with the system used in Model MC-3.

SHOCK ABSORBERS

The shock absorbers are of the heavy-duty type.

For servicing, refer to the Suspension Section of the 1958 Chrysler and Imperial Service Manual and 1959 Supplement.

2. REAR AXLE

The Rear Axle is of the same basic design as used on the Model MC-3. Standard and "Sure-Grip" axle ratio is 3.31, (43-13). For servicing, refer to the Rear Axle Section of the 1958 Chrysler and Imperial Service Manual.

3. BRAKES

The Brake System is of the same basic design as used on Model MC-3. For servicing the brakes, refer to the Brake Section of the 1958 Chrysler and Imperial Service Manual and 1959 Supplement.

4. ACCESSORY BELT DRIVES

The belt deflections remain the same as outlined in Accessory Belt Drives, Section 4, of the 1959 Chrysler and Imperial Service Manual Supplement with the exception of the fan pulley ratio which is as follows:

Standard - .95 to 1

Air Conditioning - 1.20 to 1

5. COOLING SYSTEM

The Cooling System is the same design as used on Model MC-3 except the Silent Flite Fan Drive, as shown in Figure 2, is standard equipment. A box shroud is used on cars equipped with Air Conditioning.

Adjust the carburetor for proper idle as indicated in the Fuel System Section to obtain satisfactory idle cooling. For servicing, refer to the Cooling System Section of the 1958 Chrysler and Imperial Service Manual and 1959 Supplement.

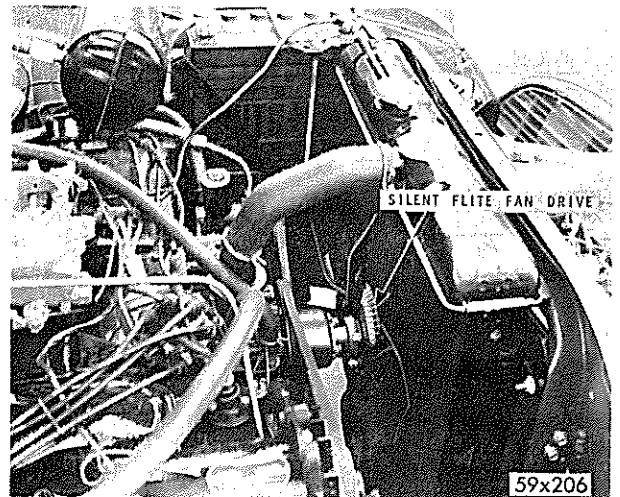

Fig. 2 - Silent Flite Fan Drive

6. ENGINE

The Chrysler 300-E is powered by a high performance version of the new 413 cubic inch engine. Some of the new features are two four-barrel carburetors, as shown in Figures 3 and 4, a special intake manifold, high performance camshaft, high load valve springs with a spiral type surge damper as shown in Figure 5, and new low reduction dual air cleaners as shown in Figure 6.

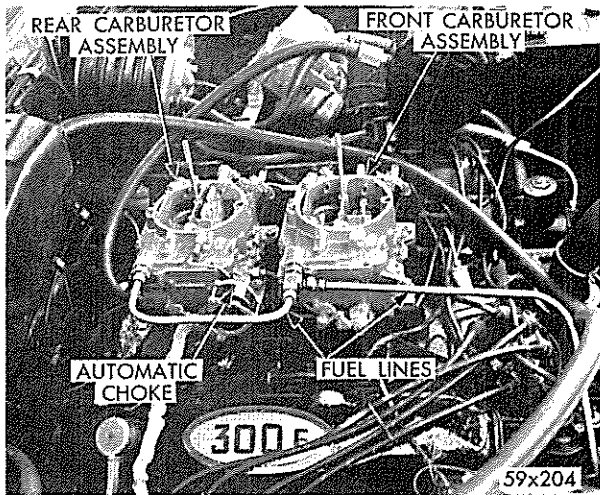

Fig. 3 - C-300E Engine
(Right Side View)

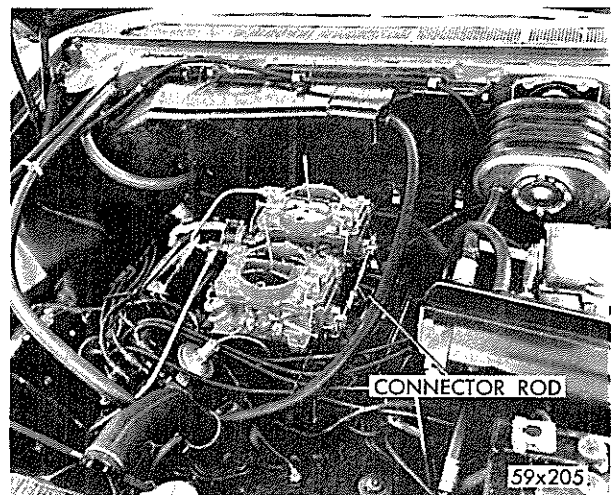

Fig. 4 - C-300E Engine
(Left Side View)

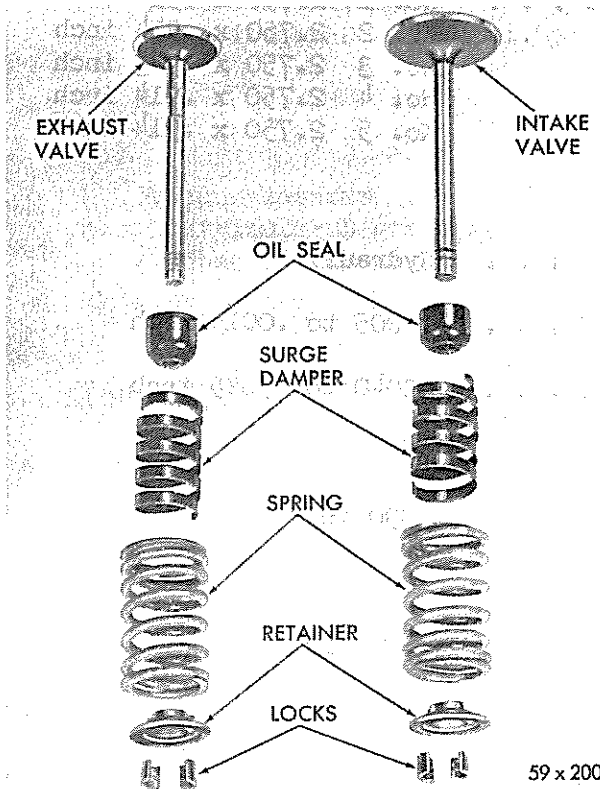

Fig. 5 - Intake and Exhaust Valves
(Disassembled View)



Fig. 6 - Carburetor Air Cleaners
Installed

Engine Idle Setting - Set idle adjustment to obtain a smooth idle at 650 rpm, as outlined in the Fuel Section of this bulletin.

Ignition Timing - Disconnect distributor vacuum line, set ignition at 10 degrees BTDC and reset engine idle back to 650 rpm if necessary.

Valve Timing Procedure - Turn the crankshaft until the No. 1 exhaust valve is full open and No. 1 piston is on TDC (following the compression stroke). Insert a 1/4 inch spacer between the rocker arm pad and the stem tip of the No. 1 intake valve (second valve on the left bank). Install a dial indicator so that the pointer contacts the valve spring retainer as nearly perpendicular as possible. Allow the spring load to bleed the tappet down, giving in effect, a solid tappet.

VALVE SPRINGS (continued)

Valve Spring installed Height (Spring Seat to Retainer)	1.830 to 1.890 inch
Recondition at	1.910 inch
Surge Damper	Spiral Type

7. ELECTRICAL SYSTEM

Electrical units are identical with those used on Model MC-3, with the exceptions listed as follows:

DISTRIBUTOR

AutoLite IBS-4010 - 1842811

Automatic Advance

Distributor Degrees and rpm	0° @ 325 to 475
	0 to 5° @ 475
	3.0 to 5.0° @ 550
	5.5 to 7.5° @ 1050

Vacuum Advance

Distributor Degrees and Inches of Vacuum	0° @ 7.5 to 9.2 inches
	6.0 to 9.0° @ 13 inches
	11.5 to 14.5° @ 18.2 inches

SPARK PLUGS

Type	A32
Thread Length.	3/8 inch
Size	14 MM
Gap.035 inch

For Service Procedures, refer to the 1959 Chrysler and Imperial Service Manual Supplement.

8. FUEL AND EXHAUST SYSTEMS

Two 4-barrel carburetors are used on the 1959 Chrysler 300-E models, as shown in Figures 7 and 8. The choke system is incorporated in the rear carburetor only. Front and rear carburetors are not interchangeable. These carburetors are basically the same as the carburetor used on the MC-2 and 3 engine except for the operation of the secondary throttle valves and the choke system.

The secondary throttle valves are mechanically connected to the primary valves and open with the primary after an approximate 3/8" lag. Velocity valves are located above the secondary throttle valves and operate when air velocity

← FRONT OF ENGINE

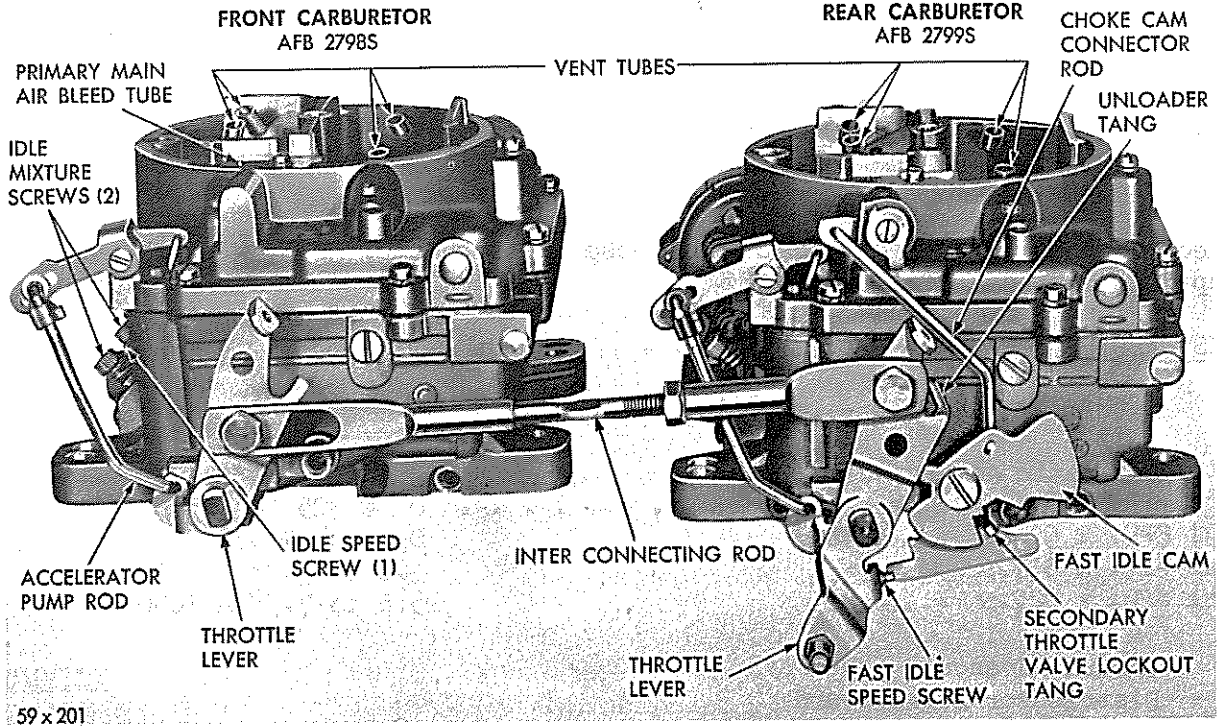

Fig. 7 - Front and Rear Carburetors (Left Side View)

FRONT OF ENGINE →

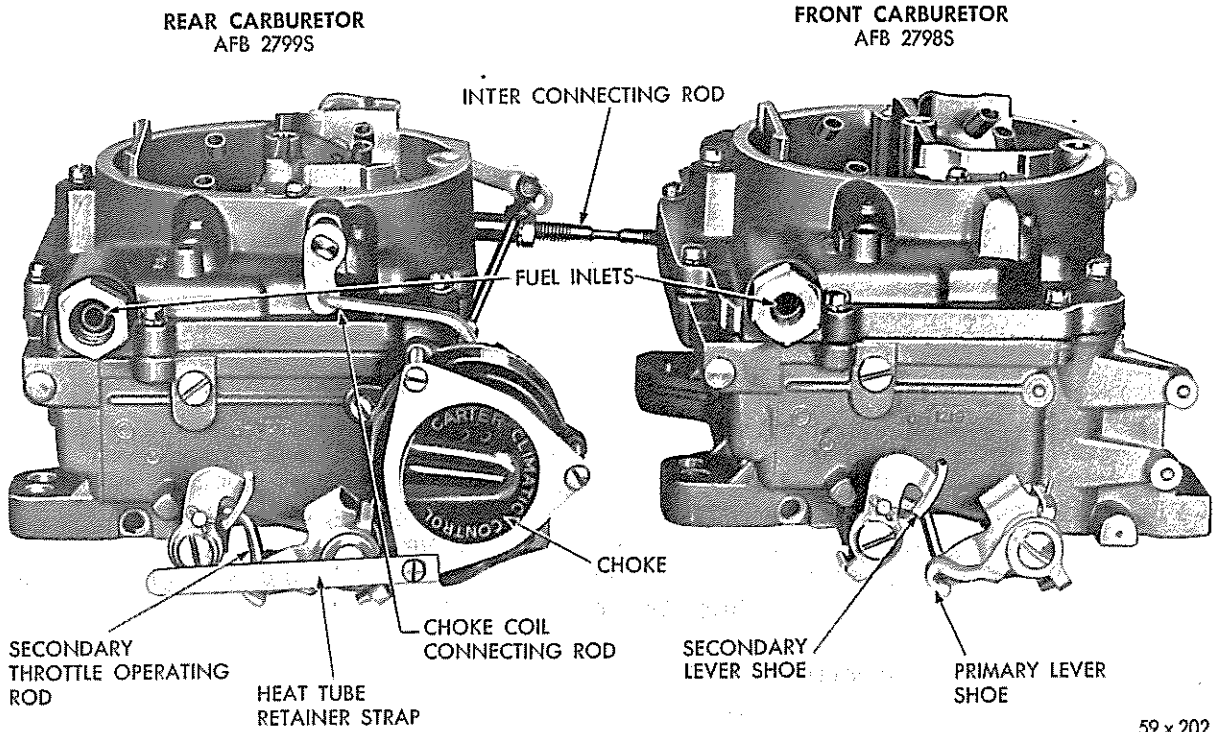

Fig. 8 - Front and Rear Carburetors (Right Side View)

8. FUEL AND EXHAUST SYSTEMS (continued)

overcomes the counterweight attached to the valve shaft, permitting the offset velocity valves to position themselves according to engine requirements. No external parts of the velocity valves can be seen from outside the carburetor.

When the engine is cold and the choke is in closed position, a mechanical latch prevents the secondary valves from opening. (This applies to rear carburetor only.) After the choke is opened fully, the latch is released, allowing operation of the secondary valves.

SERVICE PROCEDURES

In disassembling the C 300E carburetors for cleaning, inspection or overhaul, follow the same sequence of operations as outlined in your 1958 Chrysler and Imperial Service Manual and 1959 Supplement for the AFB series carburetor.

CARBURETOR ADJUSTMENTS

The following information covers only those adjustments that differ from the MC-3 and MY-1 AFB carburetor. Refer to carburetor specifications for adjustment data.

CHOKE UNLOADER ADJUSTMENT (Rear Carburetor Only)

With the primary throttle valves held in wide open position, insert 1/4 inch gauge, Tool T-109-31 between upper edge of choke valve and inner dividing wall of air horn. With finger pressing against upper part of choke valve, slight drag should be felt on gauge as it is being withdrawn.

If no drag is felt, or if too much drag is apparent, bend unloader tang on throttle lever, using Tool T-109-41.

FAST IDLE ADJUSTMENT (On bench - Rear Carburetor Only)

Insert a .013 inch wire gauge, Tool T-109-44 or drill between primary throttle valves and side of bore opposite idle adjusting screws. Move choke valve to fully closed position and adjust fast idle screw to give a slight drag on gauge when screw is resting on high step of fast idle cam at index mark on cam. Bend connecting rod at bend to correct index if necessary.

SECONDARY THROTTLE LEVER ADJUSTMENTS

Primary and secondary throttle valves should reach wide open position at the same time. To adjust, bend throttle operating rod at upper angle. With primary and secondary valves in tightly closed position, there should be a .020 inch clearance, Tool T-109-29, between positive closing shoes on primary and secondary throttle levers. To adjust, bend shoe on primary throttle lever.

SECONDARY VALVE LOCKOUT ADJUSTMENT (Rear Carburetor Only)

Make this adjustment after completing fast idle adjustment and secondary throttle lever adjustments. With the choke valve in the closed position, the tang on secondary valve shaft lever should fully engage in notch of lockout dog. Bend

SECONDARY VALVE LOCKOUT ADJUSTMENT (Rear Carburetor Only) - (continued)

tang on secondary valve shaft lever to obtain desired contact. Slowly open the choke valve. The secondary valves should become unlocked a few degrees before the choke valve reaches the wide open position.

FAST IDLE ADJUSTMENT (On Car)

Before setting fast idle, engine should be fully warmed and idling at 650 rpm (transmission in neutral). Remove the air cleaners. Stop engine and open throttle halfway. Close choke valve fully while holding throttles partially open. Let throttle close, making certain fast idle adjusting screw contacts high step of fast idle cam at index mark. Bend choke rod as necessary for indexing. Start engine without touching throttle and check engine rpm. Adjust fast idle adjusting screw until the desired 1375 to 1425 rpm has been obtained. Install Air Cleaners.

CHOKE PISTON INDEX

The choke piston can be indexed properly to improve warm-up performance. The ignition system should be in good working order and the timing checked to insure satisfactory performance. The manifold heat control valve should also be inspected carefully for proper functioning as this operation is extremely important for satisfactory warm-up performance.

With the above items checked and working properly and fully-warmed-up engine performance good, proceed as follows:

1. Remove choke housing retainer ring, heat tube cap and choke coil housing.
2. Remove throttle return spring so throttle can be set one quarter turn open.
3. Let choke blade go wide open.
4. Insert an .026 inch wire gauge* into choke piston slot so that hook on the end goes into slot in cylinder, as shown in Figure 9.

*This gauge can be made by bending a piece of .026 inch wire as shown on the attached sketch. If this size wire is not readily available, .026 inch step up wire used in BBD carburetors can be bent to shape and used for this purpose.

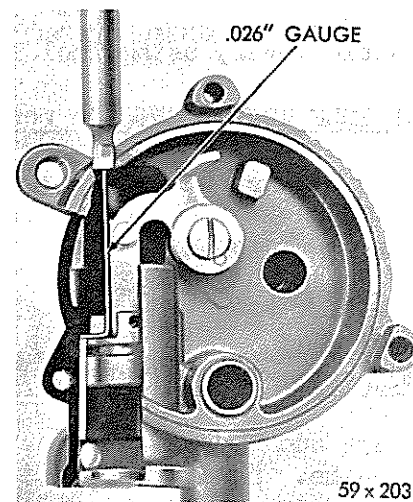

Fig. 9 - Choke Piston Index

5. Push on choke lever (clockwise) tapping the wire gauge between piston and cylinder slots with linkage hanging free.
6. Adjust the link connecting the choke shaft to the choke piston lever by bending the link at an angle to give $5/64$ " opening between choke valve and wall of air horn.

CHOKE PISTON INDEX (continued)

7. Reassemble choke, setting the coil one notch rich and install the throttle return spring.

IDLE SPEED AND MIXTURE ADJUSTMENTS (Carburetor on Engine)

CARBURETORS INTER-CONNECTING ROD

Before proceeding with carburetor adjustments, check for proper assembly and adjustment of inter-connecting rod to carburetor throttle levers. Both front and rear carburetor throttle levers should operate freely and in the same plane. If levers are bent or damaged, correct as necessary. Install the inter-connecting rod with the slotted end connected at the lower hole in the throttle lever of front carburetor and the other end connected at the top hole of rear carburetor throttle lever. To adjust, hold rear carburetor throttle in wide open position (choke in off position) and adjust rod at slotted end so front carburetor throttle valves will also be in wide open position; then tighten locknut and check operation in linkage. Make sure that the inter-connecting rod can rotate slightly on the pivots and not bind in any throttle position.

IDLE SPEED AND MIXTURE ADJUSTMENTS

Connect tachometer and warm engine to normal operating temperature so choke will be fully off and carburetor on slow idle.

CAUTION: Do not let engine become excessively warm while setting idle speeds carburetor adjustments.

Remove the inter-connecting rod at rear carburetor throttle lever. Set idle mixture screws 1 to 2 turns open. Set idle by-pass air screws 1 turn open and adjust idle speed to 650 rpm by opening or closing by-pass screw, keeping the openings equal.

NOTE: The idle by-pass air screw is located at the front of each carburetor body flange between the two idle mixture screws. It has a 7/16" slotted hex head. Adjust idle mixture screws on front carburetor for maximum rpm. Repeat on rear carburetor and readjust front carburetor if necessary. During the adjustment period, should idle speed at any time exceed 675 RPM, the idle by-pass screw must be readjusted to 650 RPM.

Before attaching the inter-connecting rod at rear carburetor, check transmission throttle linkage adjustments so that idle position is not disturbed.

EXHAUST SYSTEM

Larger exhaust pipes and low restriction mufflers are used on the C 300E.

CARBURETOR SPECIFICATIONS

Model	4 Barrel Downdraft
Front Carburetor	AFB 2798S
Rear Carburetor.	AFB 2799S
Nominal Size	1 1/4 in. bore 4 bolt
Adjustments	
Float Setting (casting to top of floats)	
Front Carburetor.	9/32 inch
Rear Carburetor	7/32 inch
Float Drop	15/16 inch
Choke Unloader	1/4 inch
Pump Setting (top of plunger to air horn).	7/16 inch
Fast Idle.013 inch on rear carburetor
Fast Idle Speed.	1400 rpm
Idle Speed	650 rpm
Idle Mixture (both screws, both carburetors). . .	Approximately 1 full turn open Set for Best Idle
Accelerator Pump	Middle Stroke (both carburetors)
Choke	
Control.	Integral Automatic
Choke Setting.	1 Notch Rich

9. FRAME

The frame is of the same basic construction as used in the MC-3 Models. For servicing of the frame, refer to Section 9 of the 1958 Chrysler and Imperial Service Manual and 1959 Supplement.

10. STEERING

The "Constant Control Full Time" Power Steering gear assemblies are of the same basic design as used on Model MC-3. For servicing of the assemblies, refer to Section 10 of the 1958 Chrysler and Imperial Service Manual and 1959 Supplement.

11. TORQUEFLITE TRANSMISSION

Servicing procedures for the TorqueFlite transmission remain essentially the same as outlined in the 1958 Chrysler and Imperial Service Manual and 1959 Supplement, with the following Exceptions:

TRANSMISSION THROTTLE LINKAGE ADJUSTMENT (Refer to Figure 10)

Run engine until normal operating temperature is reached. Remove rear carburetor air cleaner and check that the choke is in a fully opened position. Connect tachometer to coil and ground. Adjust and set engine idle as described under "Idle Speed and Mixture Adjustment" and set carburetors inter-connecting rod as described under "Carburetors Inter-Connecting Rod Adjustment", of this bulletin.

Unsnap accelerator shaft to carburetor rod assembly from ball joint on rear carburetor throttle lever. Move the rod rearward until rod is stopped by the idle stop on the transmission idle cam. With rod lightly preloaded against transmission idle cam stop, ball joint (on rear carburetor throttle lever) should be in alignment with ball joint clip on accelerator shaft to carburetor rod. If not in alignment, lengthen or shorten rod adjustable end (threaded) until alignment is obtained, then engage ball joint with rod end clip.

Start engine and recheck setting (600-650 rpm) with N (Neutral) push button engaged and handbrake applied. Check the accelerator pedal angle to make sure

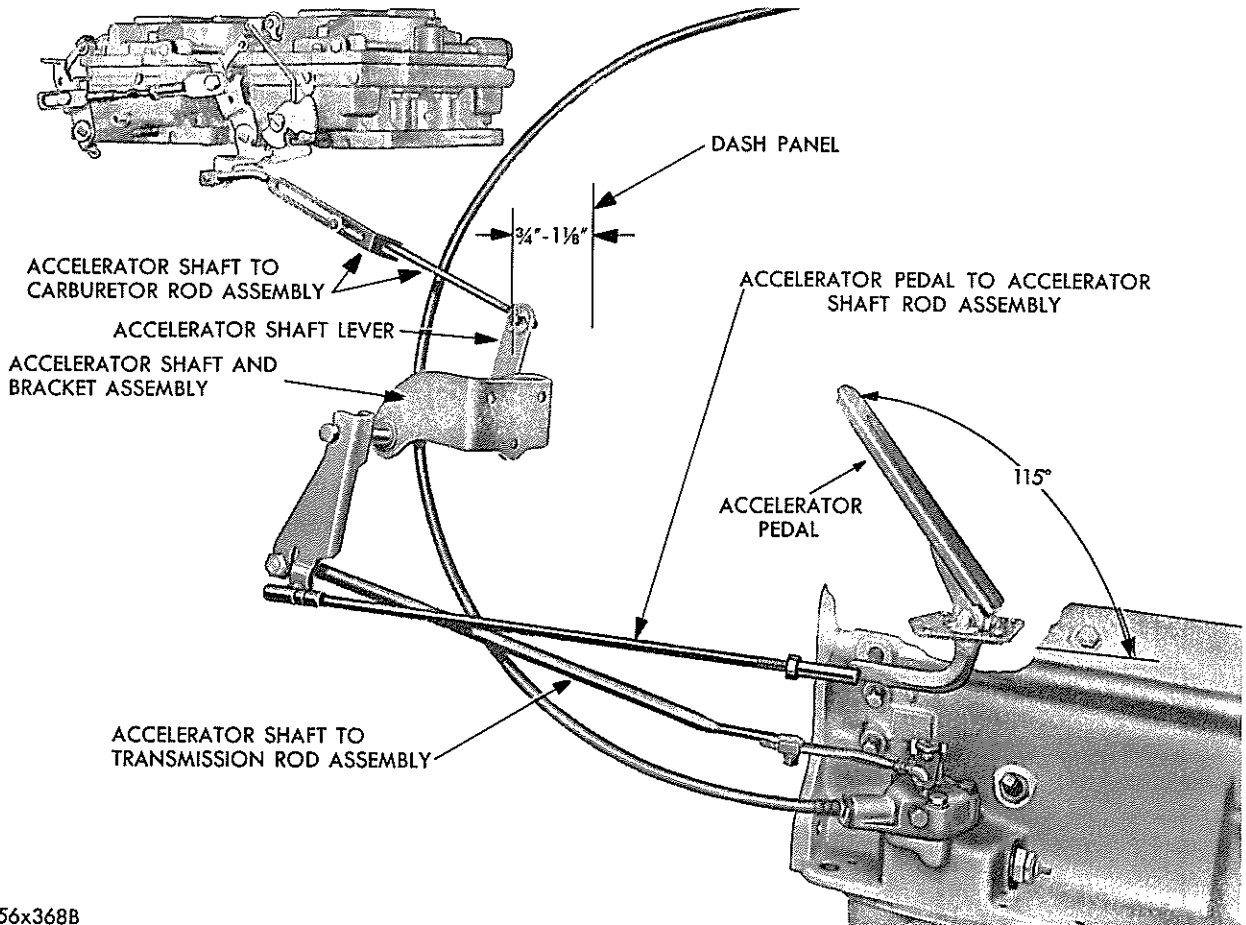

56x368B

Fig. 10 - Transmission Throttle Linkage

TRANSMISSION THROTTLE LINKAGE ADJUSTMENT (continued)

it is 115 degrees to the horizontal, as shown in Figure 9. Proper pedal angle is obtained by adjusting the accelerator pedal to accelerator shaft rod length at the ball joint located on the accelerator pedal end. Check for any binding in the throttle linkage and correct if present. All TorqueFlite transmission equipped cars have a throttle linkage adjustment at the transmission throttle operating lever. The purpose of this adjustment is to allow for permissible variations between body and engine locations in manufacturing and should not be used for making the throttle linkage adjustment.

If, after making adjustment, satisfactory performance is still not obtained, check to see if the correct accelerator shaft lever assembly has been used. The shaft lever must be 3 1/4 inches in length between center line of hole diameters (2 7/8 inches when used with two barrel carburetor).

When linkage is correctly installed, a clearance of 3/4 - 1 1/8 inch should exist between dash panel and center of accelerator shaft to carburetor rod pin as shown in Figure 10.

GOVERNOR ASSEMBLY

Should it ever become necessary to replace either the governor weights (inner or outer) and/or weight spring (Figure 11), it is essential that the following parts be used:

<u>Part Name</u>	<u>Part Number</u>
Outer Weight	1823726
Inner Weight	1636462
Spring	1823709

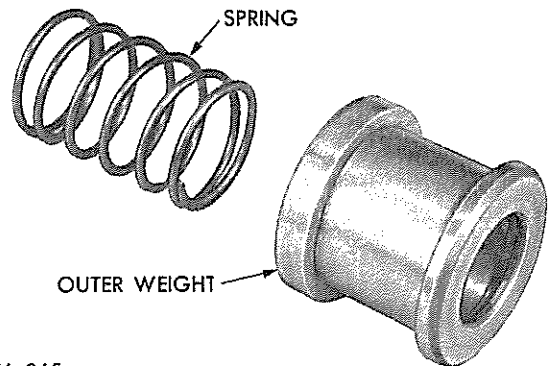

Be sure to recheck governor pressure.
See Governor Pressure Chart - Next Paragraph.

56x365

Fig. 11 - Transmission Governor Outer Weight and Spring

PRESSURE CHECKS

Pressure check procedures remain unchanged, except for governor values which are given in the following chart:

GOVERNOR PRESSURE CHART

Governor Pressure	(3.31:1 AXLE RATIO)
	Vehicle Speed (in miles per hour)
15 psi.	21-23
50 psi.	48-53
75 psi.	71-77

NOTE: All shift speeds may vary somewhat due to production tolerances and rear axle ratios - which is not too important, however, the quality of the shifts is very important. All shifts should be smooth, responsive, and with no noticeable engine runaway. Slight variations in above pressures are permissible, and no corrective action should be taken unless a definite problem exists with shift pattern or shift quality, assuming that no speedometer error exists.

1. Adjustments and inspection recommended during warranty period.
 - a. Kickdown band adjustment.
 - b. Throttle linkage adjustment.
 - c. Check and adjust transmission oil level.
2. Adjustments and inspection recommended every 10,000 miles.
 - a. Remove oil pan and clean intake screen.
 - b. Adjust kickdown band.
 - c. Adjust low-reverse band.
 - d. Change transmission fluid.
 - e. Check and if necessary, adjust torqueflite line pressure.
It should be 89 to 91 psi at 1200 engine rpm.

12. UNIVERSAL JOINTS AND PROPELLER SHAFT

The universal joint is of the same basic design as used in the MC-3.

A heavier ribbed front universal joint dust cover boot is used to prevent boot collapsing due to higher speed.

For Service Procedures, refer to 1958 Chrysler and Imperial Service Manual, D-16350.

13. WHEELS AND TIRES

The Hi-Speed Super Cushion Nylon Special Blue Streak tubeless tires (white - sidewall) (9.00 x 14) are standard equipment on the 300 E.

For Service Procedures, refer to the 1958 Chrysler and Imperial Service Manual and 1959 Supplement.

14. BODY AND SHEET METAL

The basic body to frame assemblies are similar to the MC-3 standard body. The hood panel, hood lock, front fender assembly and radiator grille are entirely different from other Chrysler Models, and the front bumper and chrome moulding have also been modified. The roof panel, compound windshield and rear glass, for the Special Club Coupe are the same as used on Chrysler Special Club Models. The convertible windshield, folding top and rear curtain are the same as used on the MC-3 convertibles.

14. BODY AND SHEET METAL (continued)

The door and quarter glass and panels are the same as used on the MC-3 Special Club Coupe and Convertibles, respectively, except that new chrome moulding attaching holes must be drilled in panels to correspond with the body trim mouldings, therefore, doors and quarter panels should be obtained without moulding holes. The rear deck lid has been modified with standard deck latch and lock assembly. Use deck lid less holes, drill to suit.

Swivel seats are standard equipment on the Chrysler 300-E. Installation, removal and servicing of body components are similar to the procedures in the 1959 Chrysler and Imperial Service Supplement.

15. LUBRICATION

Follow the same recommendations as used on Model MC-3. Refer to the 1959 Chrysler and Imperial Service Manual Supplement.

16. RADIO AND HEATER

Radio and heater models are identical with those used on the MC-3.

For Service Procedures, refer to the 1959 Chrysler and Imperial Service Manual Supplement.

17. HEATER - AIR CONDITIONING

The Heater-Air Conditioning Unit used in the C 300-E is identical with the unit used in Model MC-3.

Service Procedures are the same as outlined in the 1959 Chrysler and Imperial Service Manual Supplement.